



HOSHIZAKI

UNDERCOUNTER FREEZER

FT-158MA-S-ML FT-156MA-S-ML

A-FIT cabinets are designed to show outstanding performance and durability backed by Hoshizaki's many years of experience and high-quality standard. The cabinets combine ergonomic design with high functionality and strong cooling capacity to meet customer high expectations.



KEY FEATURES

- > Pillar-less design for easy loading of large pans & trays
- > Enhanced cooling capacity with larger evaporator and stronger cooling fan
- > Cleaning-free condenser
- > Ergonomic full-height door
- > HACCP complied design
- > Forced evaporation system
- > Smart auto-defrost system
- > Field reversible door
- > LED interior lighting
- > Removable door gaskets

CERTIFICATION



DIMENSIONS & SPECIFICATION

FT-158MA-S-ML

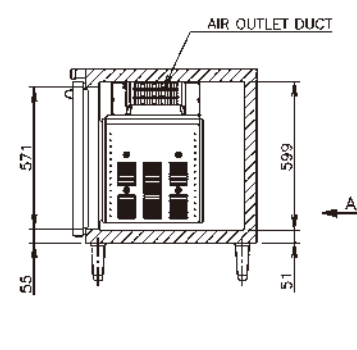
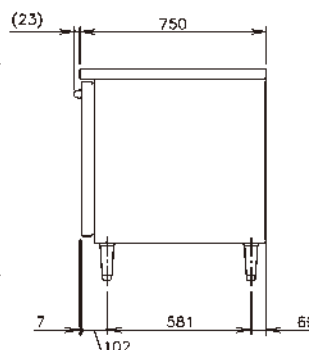
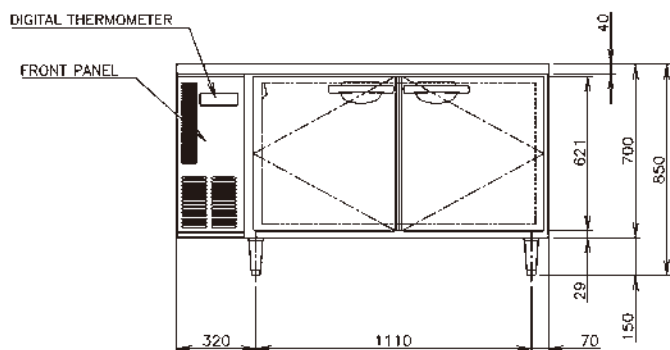
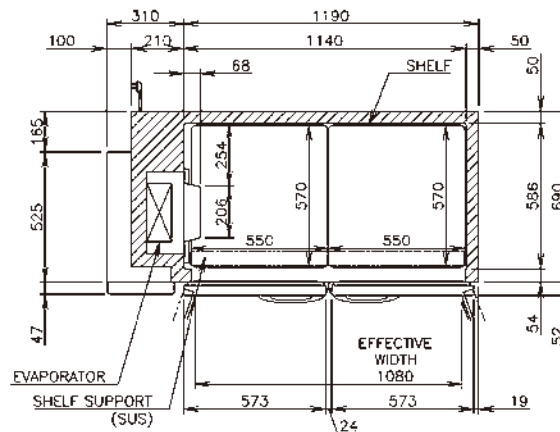
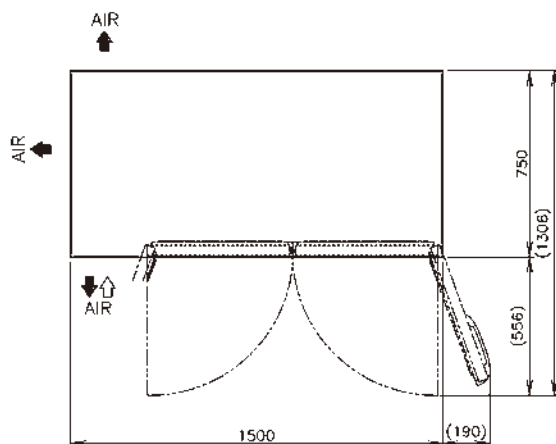
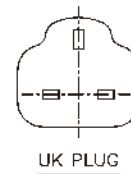
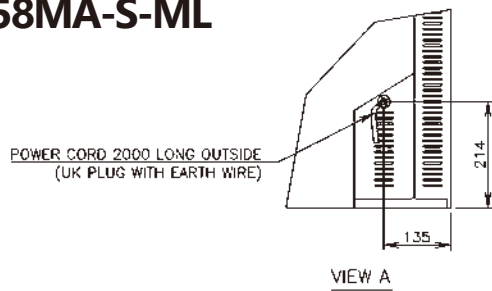

MODEL	FT-158MA-S-ML	FT-156MA-S-ML
TEMP. CONTROL	-23 to -7°C	-23 to -7°C
EFFECTIVE CAPACITY	420 L	318 L
WEIGHT	89kg (Gross: Approx. 94kg)	81 kg (Gross: Approx. 86kg)
OUTSIDE DIMENSIONS W x D x H (mm)	1500 x 750 x 850(-880)	1500 x 600 x 850(-880)
PACKAGE W x D x H (mm)	1565 x 830 x 790	1565 x 680 x 790
POWER SUPPLY	1 Phase 230V 50Hz Capacity: 0.9kVA (4.08A)	1 Phase 230V 50Hz Capacity: 0.9kVA (4.08A)
ELECTRIC CONSUMPTION	415W Heater: 371W Refrigeration 333W Defrost: 330W	415W Heater: 371W Refrigeration 349W Defrost: 330W
AMPERAGE	Rated 2.7A	Rated 2.6A
SHELF	4pcs.	4pcs.
OPERATING CONDITION	Ambient Temperature: 5-38°C Voltage Range: Rated Voltage ±6%	Ambient Temperature: 5-38°C Voltage Range: Rated Voltage ±6%

We reserve the right to make changes in specification and design without prior notice. WWW.HOSHIZAKI.COM



HOSHIZAKI

18 Boon Lay Way #01-102 Tradehub 21, 609966
TEL 6225 2612 FAX 6225 3219 www.hoshizaki.com.sg