



HOSHIZAKI

UNDERCOUNTER SLIDING GLASS DOOR REFRIGERATOR

RT-156MA-SSG

A-FIT cabinets are designed to show outstanding performance and durability backed by Hoshizaki's many years of experience and high-quality standard. The cabinets combine ergonomic design with high functionality and strong cooling capacity to meet customer high expectations.



KEY FEATURES

- > Low-E glass with argon gas for better heat insulation
- > Requires less space compared to a swing door design
- > Enhanced cooling capacity with larger evaporator and stronger cooling fan
- > Ergonomic full-height door
- > HACCP complied design
- > Forced evaporation system
- > Smart auto-defrost system
- > LED interior lighting

CERTIFICATION



DIMENSIONS & SPECIFICATION

RT-156MA-SSG

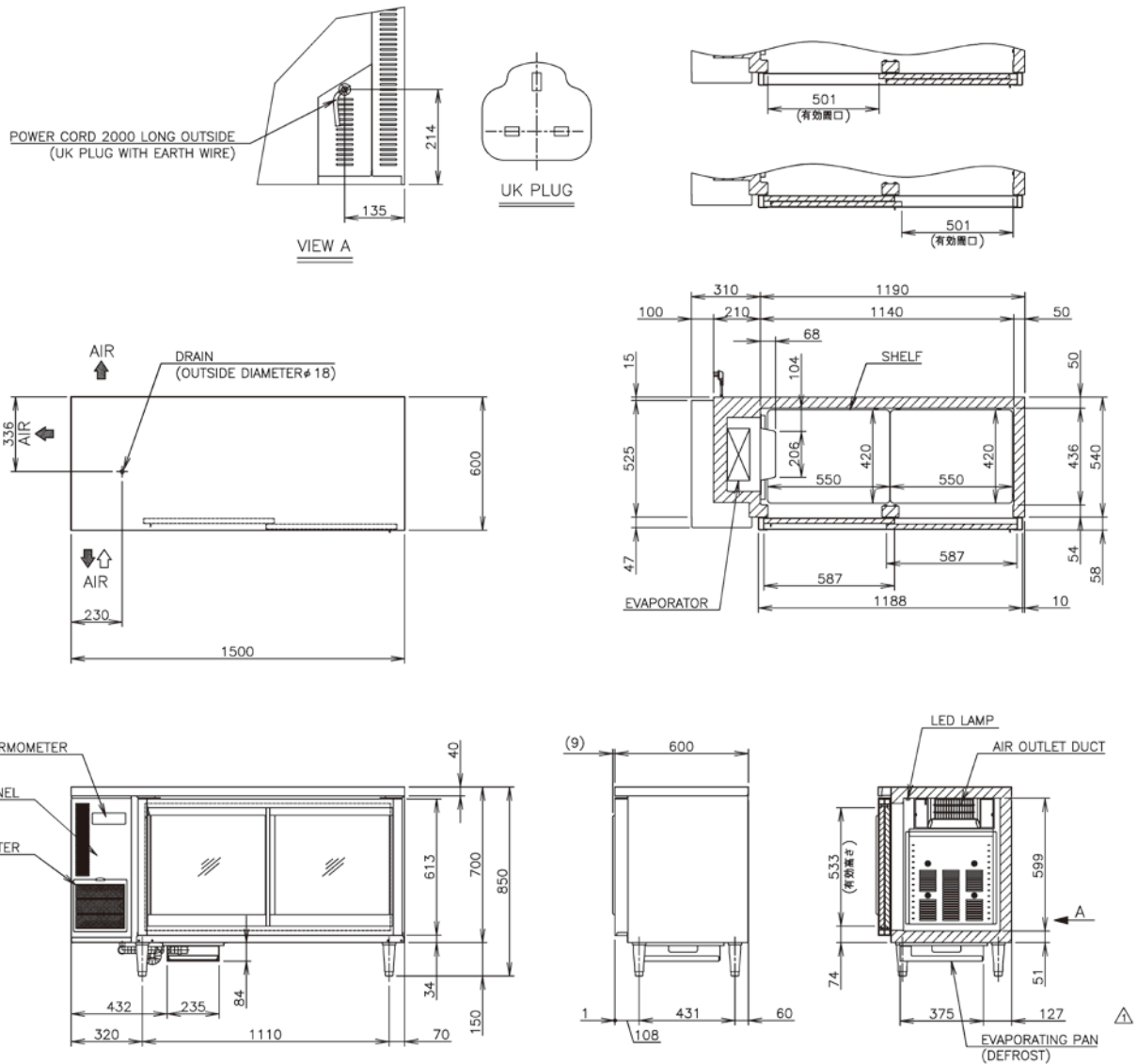

| MODEL | RT-156MA-SSG |
|-----------------------------------|----------------------------------------------------------------|
| TEMP. CONTROL | -2 to 12°C |
| EFFECTIVE CAPACITY | 318 L |
| WEIGHT | Net : 98 kg (Gross : Approx. 103 kg) |
| OUTSIDE DIMENSIONS W x D x H (mm) | 1500 x 600x 850 (-880) |
| PACKAGE W x D x H (mm) | 1565 x 680 x 790 |
| POWER SUPPLY | 1 Phase 220 - 240V 50Hz Capacity: 0.50kVA (2.27A) |
| ELECTRIC CONSUMPTION | Motor: 258 W Heater: 81 W Refrigeration: 315 W Defrost: 81 W |
| AMPERAGE | Rated: 2.0A |
| SHELF | 4 pcs. |
| OPERATING CONDITION | Ambient Temperature: 5 - 38°C Voltage Range: Rated Voltage ±6% |

We reserve the right to make changes in specification and design without prior notice. WWW.HOSHIZAKI.COM



HOSHIZAKI

18 Boon Lay Way #01-102 Tradehub 21, 609966
TEL 6225 2612 FAX 6225 3219 www.hoshizaki.com.sg

DIMENSIONS & SPECIFICATION

RT-156MA-SSG

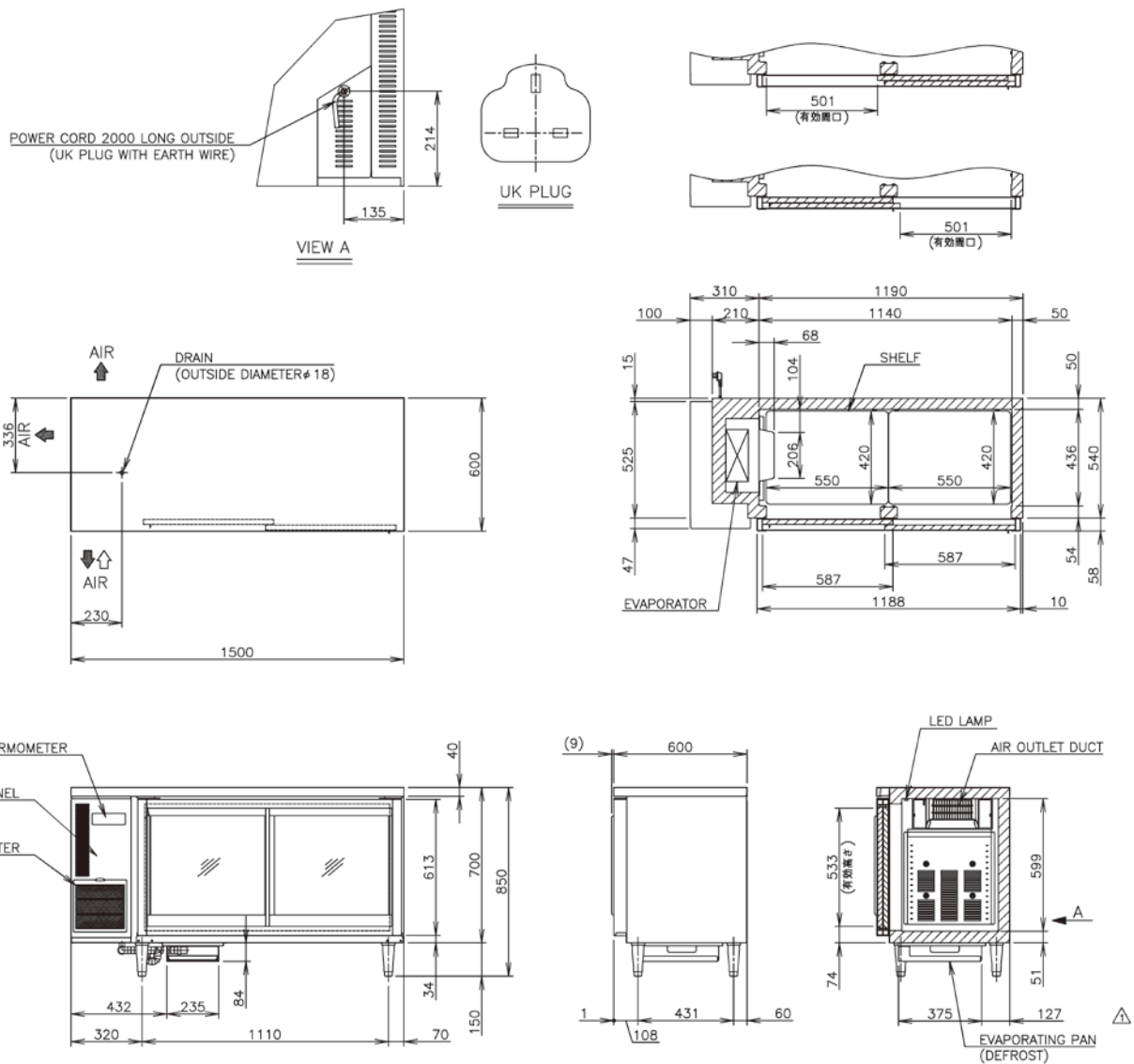

| MODEL | RT-156MA-SSG |
|-----------------------------------|----------------------------------------------------------------|
| TEMP. CONTROL | -2 to 12°C |
| EFFECTIVE CAPACITY | 318 L |
| WEIGHT | Net : 98 kg (Gross : Approx. 103 kg) |
| OUTSIDE DIMENSIONS W x D x H (mm) | 1500 x 600x 850 (-880) |
| PACKAGE W x D x H (mm) | 1565 x 680 x 790 |
| POWER SUPPLY | 1 Phase 220 - 240V 50Hz Capacity: 0.50kVA (2.27A) |
| ELECTRIC CONSUMPTION | Motor: 258 W Heater: 81 W Refrigeration: 315 W Defrost: 81 W |
| AMPERAGE | Rated: 2.0A |
| SHELF | 4 pcs. |
| OPERATING CONDITION | Ambient Temperature: 5 - 38°C Voltage Range: Rated Voltage ±6% |

We reserve the right to make changes in specification and design without prior notice. WWW.HOSHIZAKI.COM



HOSHIZAKI