



HOSHIZAKI

UPRIGHT DUAL TEMP.

HRF-78MB-S

A-FIT cabinets are designed to show outstanding performance and durability backed by Hoshizaki's many years of experience and high-quality standard. The cabinets combine ergonomic design with high functionality and strong cooling capacity to meet customer high expectations.



KEY FEATURES

- > Enhanced cooling capacity with larger evaporator and stronger cooling fan
- > Cleaning-free condenser
- > Ergonomic full-height door
- > HACCP complied design
- > Forced evaporation system
- > Smart auto-defrost system
- > Field reversible door
- > LED interior lighting
- > Removable door gaskets

CERTIFICATION



DIMENSIONS & SPECIFICATION

HRF-78MB-S

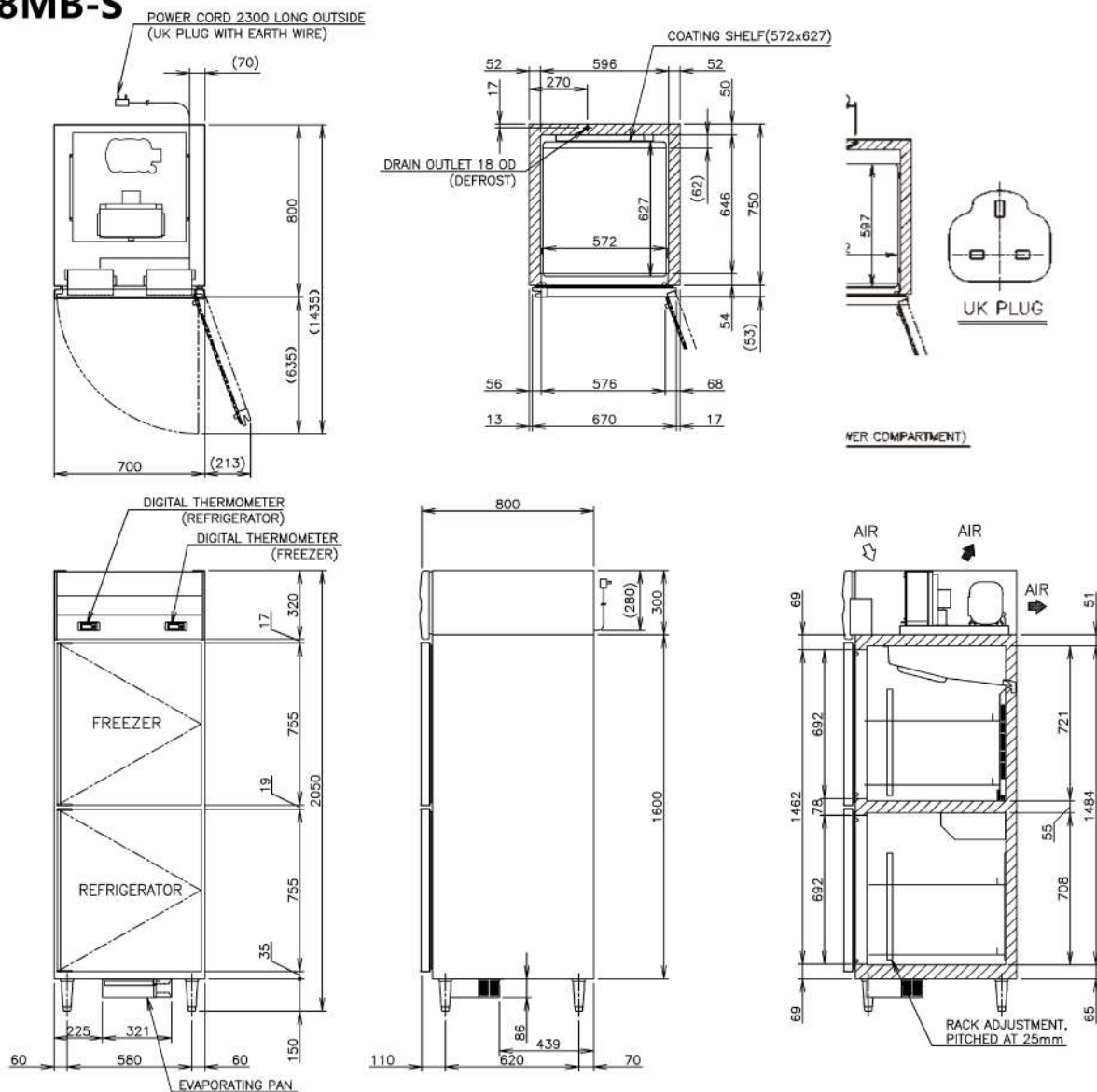

MODEL	HRF-78MB-S
TEMP. CONTROL	Refrigerator : -2 to 12°C Freezer: -23 to -11°C
EFFECTIVE CAPACITY	Total 448L (Refrigerator : 234L, Freezer : 214L)
WEIGHT	119 kg(Gross 139kg)
OUTSIDE DIMENSIONS W x D x H (mm)	700 x 800 x 2050 (-2080)
PACKAGE W x D x H (mm)	760 x 900 x 2075
POWER SUPPLY	1 Phase 220 -240V 50Hz Capacity : 1.12kVA (5.10A)
ELECTRIC CONSUMPTION	576 W Heater : 426W Defrost: 250W
AMPERAGE	Rated : 4.3A
SHELF	4 pcs
OPERATING CONDITION	Ambient Temperature : 5 - 43°C Voltage Range : Rated Voltage $\pm 6\%$