

MP80X

Mixer for pastry ice-cream parlour catering and bakery



OPTIONS AND ACCESSORIES

- Reduction kit from 80lt to 40lt with nr. 3 accessories
- Reduction kit from 80lt to 60lt with nr. 3 accessories
- Bowl-Holder trolley

EXTERNAL CONSTRUCTION

- Structure in powder painted stainless steel
- Bowl and protections in stainless steel
- Replaceable whisk with thin stainless steel wires
- Spatula and spiralized hook in aluminium alloy
- Thick frame to avoid vibrations in every working phase
- Structure with adjustable rear stabilizers
- Protection grate equipped with sliding sheet for ingredients topping up
- Rotating protection grate easily removable for cleaning
- Digital push-button panel with 2 displays on top side
- General switch on right side

INTERNAL CONSTRUCTION

- Inverter for the continuous variation of the tool rotation speed
- Toothed belt driving
- Rotating parts of the transmission system on rolling bearings
- Electrical equipment with low-voltage auxiliary circuits
- Protection grate, arm and bowl in position limit switch
- Tools fast uncoupling
- Slides for the bowl uplift by gearmotor

FUNCTIONING

- Dough homogeneity and oxygenation by the combined planetary rotating and eccentric movement of the tool
- Digital programmable control of a variable speed with the possibility to program in advance 4 different speeds
- Possibility to mix a maximum volume of 80lt
- The tools can whip mix and partially knead in few minutes different food products
- Removable bowl automatically fixed in working position

STANDARD EQUIPMENT

- Whisk with thin wire
- Spatula
- Spiralized hook
- "French" shake bowl
- Electrical bowl uplift
- Multispeed inverter
- Manual or automatic working cycle
- 99 programs with the possibility to set up 3 different speeds into the same working cycle
- Self diagnostic with error message display



MORETTI FORNI S.P.A.

www.morettiforni.com

info@morettiforni.com

Via A.Meucci, 4 - 61037 Mondolfo (PU) ITALIA

Tel. +39.0721.96161 - Fax +39.0721.9616299



MP80X

RIGHT SIDE VIEW

FRONTALE VIEW

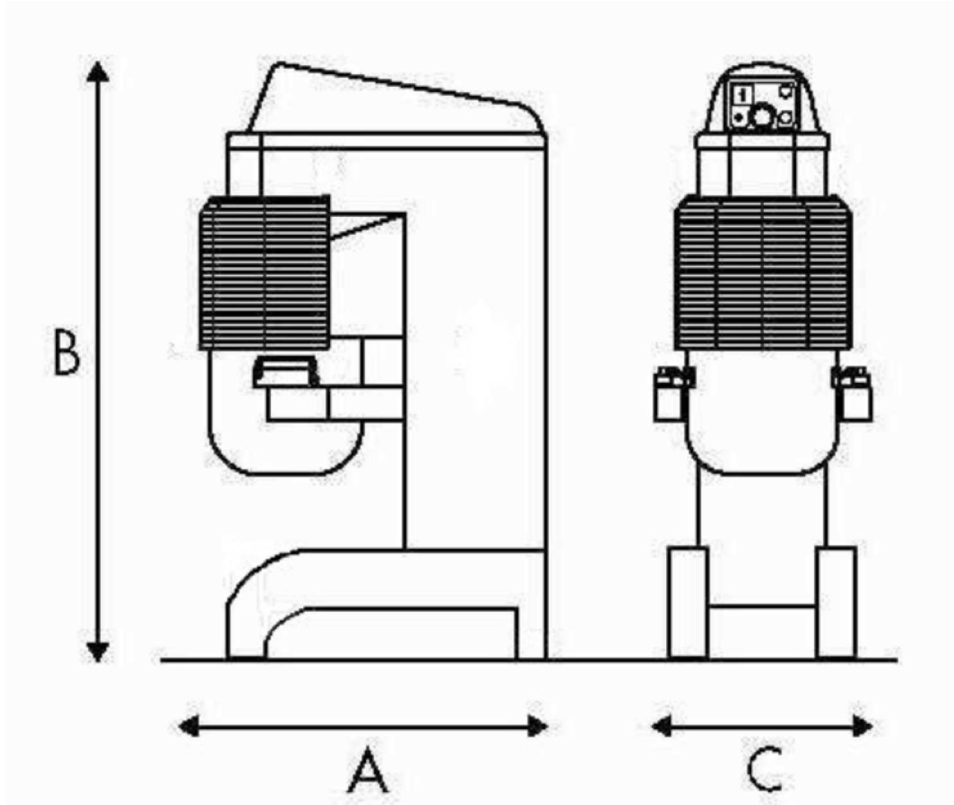

SPECIFICATIONS

This is a very versatile machinery used as Mixer to whip Eggs or Cream and partially as Dough Mixer. Ideal for little spaces. It is manufactured in high quality and rugged materials. Thanks to the tool particular form and to its planetary rotating and eccentric movement, the mixer can whip and mix in short time a maximum volume of 80lt with an optimal homogeneity and oxygenation. Electrical bowl uplift along slides by mean of a gearmotor. The transmission system is particularly noiseless because every part is on rolling bearings. The machinery has a multispeed inverter, an electronic control with 99 programs and it is equipped with the necessary safety devices.

TECHNICAL FEATURES

DIMENSIONS

Ext. depth (A)	1000mm
Ext. height (B)	1600mm
Ext. width (C)	680mm
Weight	300kg

SHIPMENT INFORMATION

Packed machinery:	
Max depth	1160mm
Max height	1750mm
Max width	810mm
Weight	(300+60)kg

FEEDING AND POWER

<i>Standard feeding</i>	
A.C. V400 3 50Hz (60Hz opt.)	
<i>Feeding on request</i>	
A.C. V230 3 50Hz (60Hz opt.)	

BOWL CAPACITY

Capacity (volume)	80lt
Bowl internal feed	480mm
Bowl internal height	500mm

Max power 3kW