

MP60V

Mixer for pastry ice-cream parlour catering and bakery



OPTIONS AND ACCESSORIES

- Reduction kit from 60lt to 20lt with nr. 3 accessories
- Reduction kit from 60lt to 40lt with nr. 3 accessories
- Bowl-Holder trolley

EXTERNAL CONSTRUCTION

- Structure in powder painted stainless steel
- Bowl and protections in stainless steel
- Replaceable whisk with thin stainless steel wires
- Spatula and spiralized hook in aluminium alloy
- Thick frame to avoid vibrations in every working phase
- Structure with adjustable rear stabilizers
- Protection grate equipped with sliding sheet for ingredients topping up
- Rotating protection grate easily removable for cleaning
- Push-button panel on top side
- General switch on right side

INTERNAL CONSTRUCTION

- Inverter for the continuous variation of the tool rotation speed
- Toothed belt driving
- Rotating parts of the transmission system on rolling bearings
- Electrical equipment with low-voltage auxiliary circuits
- Protection grate, arm and bowl in position limit switch
- Tools fast uncoupling
- Slides for the manual bowl uplift by leverage

FUNCTIONING

- Dough homogeneity and oxygenation by the combined planetary rotating and eccentric movement of the tool
- Possibility to mix a maximum volume of 60lt
- The tools can whip mix and partially knead in few minutes different food products
- Removable bowl automatically fixed in working position

STANDARD EQUIPMENT

- Whisk with thin wire
- Spatula
- Spiralized hook
- "French" shake bowl
- Lever for the manual bowl uplift
- Multispeed inverter
- Switching-off Timer



MORETTI FORNI S.P.A.

www.morettiforni.com

info@morettiforni.com

Via A.Meucci, 4 - 61037 Mondolfo (PU) ITALIA

Tel. +39.0721.96161 - Fax +39.0721.9616299



MP60V

RIGHT SIDE VIEW

FRONTALE VIEW

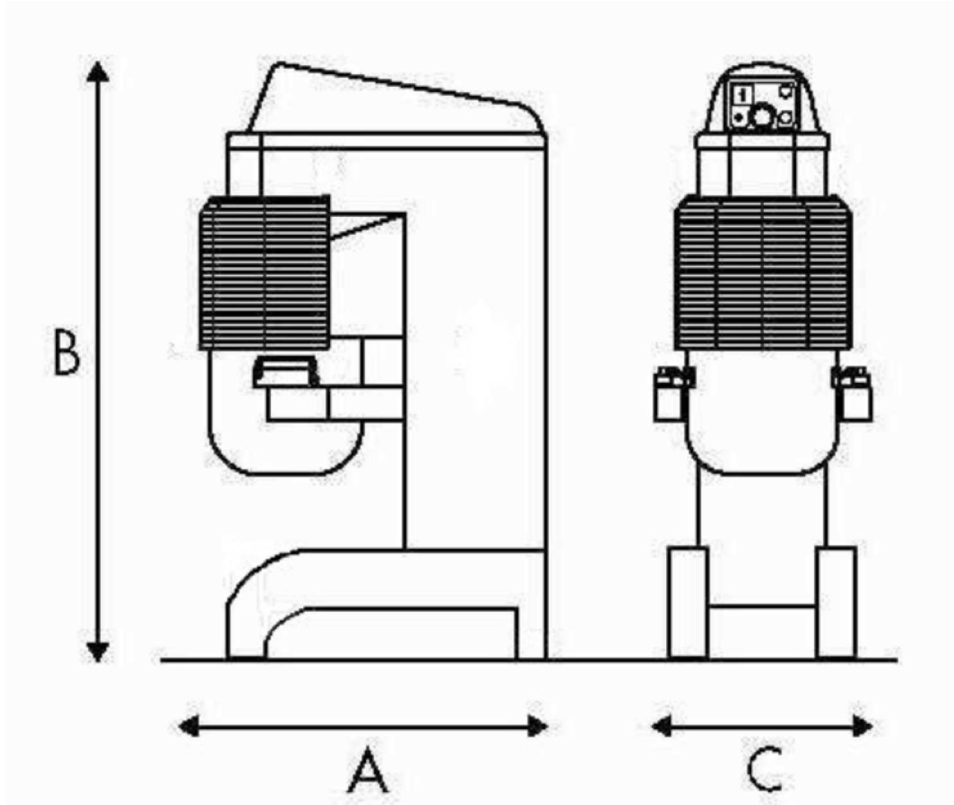

SPECIFICATIONS

This is a very versatile machinery used as Mixer to whip Eggs or Cream and partially as Dough Mixer. Ideal for little spaces. It is manufactured in high quality and rugged materials. Thanks to the tool particular form and to its planetary rotating and eccentric movement, the mixer can whip and mix in short time a maximum volume of 60lt with an optimal homogeneity and oxygenation. Manual bowl uplift on slides by mean of leverage. The transmission system is particularly noiseless because every part is on rolling bearings. The machinery has a multispeed inverter and it is provided of the necessary safety devices.

TECHNICAL FEATURES

DIMENSIONS

Ext. depth (A)	1000mm
Ext. height (B)	1600mm
Ext. width (C)	680mm
Weight	280kg

BOWL CAPACITY

Capacity (volume)	60lt
Bowl internal feed	450mm
Bowl internal height	430mm

SHIPMENT INFORMATION

Packed machinery:	
Max depth	1160mm
Max height	1750mm
Max width	810mm
Weight	(280+60)kg

FEEDING AND POWER

<i>Standard feeding</i>	
A.C. V400 3 50Hz (60Hz opt.)	
<i>Feeding on request</i>	
A.C. V230 3 50Hz (60Hz opt.)	

Max power 3kW